

Load Rating Chart

Model 4596T

Manitex

© Manitex 2000

NOTE: Additional copies of this Load Rating Chart can be purchased from your Manitex Distributor. When ordering, use the part number shown in the bottom left corner of this page.

LMI OPERATING CODES

CODE	CRANE CONFIGURATION	OUTRIGGER CONFIGURATION	AREA OF OPERATION
#1	MAIN BOOM	FULLY EXTENDED	OVER REAR
#2	MAIN BOOM	FULLY EXTENDED	180° OVER REAR
#3	MAIN BOOM	FULLY EXTENDED	FULL 360°
#4	MAIN BOOM	MID POSITION	FULL 360°
#5	MAIN BOOM	RETRACTED	FULL 360°
#6	MAIN BOOM	ON TIRES	DIRECTLY OVER REAR
#7	RETRACTED JIB 0° OFFSET	FULLY EXTENDED	OVER REAR
#8	RETRACTED JIB 0° OFFSET	FULLY EXTENDED	180° OVER REAR
#9	RETRACTED JIB 15° OFFSET	FULLY EXTENDED	OVER REAR
#10	RETRACTED JIB 15° OFFSET	FULLY EXTENDED	180° OVER REAR
#11	RETRACTED JIB 30° OFFSET	FULLY EXTENDED	OVER REAR
#12	RETRACTED JIB 30° OFFSET	FULLY EXTENDED	180° OVER REAR
#13	EXTENDED JIB 0° OFFSET	FULLY EXTENDED	OVER REAR
#14	EXTENDED JIB 0° OFFSET	FULLY EXTENDED	180° OVER REAR
#15	EXTENDED JIB 15° OFFSET	FULLY EXTENDED	OVER REAR
#16	EXTENDED JIB 15° OFFSET	FULLY EXTENDED	180° OVER REAR
#17	EXTENDED JIB 30° OFFSET	FULLY EXTENDED	OVER REAR
#18	EXTENDED JIB 30° OFFSET	FULLY EXTENDED	180° OVER REAR
#19	RETRACTED JIB 0° OFFSET	MID POSITION	180° OVER REAR
#20	RETRACTED JIB 15° OFFSET	MID POSITION	180° OVER REAR
#21	RETRACTED JIB 30° OFFSET	MID POSITION	180° OVER REAR
#22	EXTENDED JIB 0° OFFSET	MID POSITION	180° OVER REAR
#23	EXTENDED JIB 15° OFFSET	MID POSITION	180° OVER REAR
#24	EXTENDED JIB 30° OFFSET	MID POSITION	180° OVER REAR
#25	PERSONNEL LIFTING MAIN BOOM	FULLY EXTENDED	180° OVER REAR
#26	PERSONNEL LIFTING RETR JIB 0° OFFSET	FULLY EXTENDED	180° OVER REAR
#27	PERSONNEL LIFTING RETR JIB 15° OFFSET	FULLY EXTENDED	180° OVER REAR
#28	PERSONNEL LIFTING RETR JIB 30° OFFSET	FULLY EXTENDED	180° OVER REAR
#29	PERSONNEL LIFTING EXTENDED JIB 0° OFFSET	FULLY EXTENDED	180° OVER REAR
#30	PERSONNEL LIFTING EXTENDED JIB 15° OFFSET	FULLY EXTENDED	180° OVER REAR
#31	PERSONNEL LIFTING EXTENDED JIB 30° OFFSET	FULLY EXTENDED	180° OVER REAR

WARNING

1. THE OPERATOR MUST READ AND UNDERSTAND THE OWNER'S MANUAL BEFORE OPERATING THIS CRANE.
2. POSITIONING OR OPERATION OF CRANE BEYOND AREAS SHOWN ON THIS CHART IS NOT INTENDED OR APPROVED EXCEPT WHERE SPECIFIED IN OWNER'S MANUAL.
3. LOADED BOOM ANGLES AT SPECIFIED BOOM LENGTHS GIVE ONLY AN APPROXIMATION OF THE OPERATING RADIUS. THE BOOM ANGLE BEFORE LOADING SHOULD BE GREATER TO ACCOUNT FOR DEFLECTIONS. DO NOT EXCEED THE OPERATING RADIUS FOR RATED LOADS.
4. THE OPERATING RADIUS SHOWN IN THE JIB RATING CHART IS FOR FULLY EXTENDED BOOM ONLY. WHEN BOOM IS NOT FULLY EXTENDED, USE ONLY LOADED BOOM ANGLE TO DETERMINE LOAD RATING OF JIB.
5. FOR BOOM ANGLES NOT SHOWN ON JIB LOAD RATING CHART, USE RATING OF NEXT LOWER BOOM ANGLE.

WARNING (CONTINUED)

6. FOR BOOM LENGTHS NOT SHOWN, USE RATING OF NEXT SHORTER OR LONGER BOOM LENGTH, WHICHEVER IS LESS. FOR RADII NOT SHOWN, USE RATING OF NEXT LONGER RADIUS.
7. CRANE LOAD RATINGS ON OUTRIGGERS ARE BASED ON FREELY SUSPENDED LOADS WITH THE MACHINE LEVELED AND STANDING ON A FIRM UNIFORM SUPPORTING SURFACE. NO ATTEMPT SHALL BE MADE TO MOVE A LOAD HORIZONTALLY ON THE GROUND IN ANY DIRECTION.
8. PRACTICAL WORKING LOADS DEPEND ON SUPPORTING SURFACE, WIND, AND OTHER FACTORS AFFECTING STABILITY SUCH AS HAZARDOUS SURROUNDINGS, EXPERIENCE OF PERSONNEL, AND PROPER HANDLING, ALL OF WHICH MUST BE TAKEN INTO ACCOUNT BY THE OPERATOR.
9. THE MAXIMUM LOAD WHICH MAY BE TELESCOPED IS LIMITED BY HYDRAULIC PRESSURE, BOOM ANGLE, AND BOOM LUBRICATION. IT IS SAFE TO ATTEMPT TO TELESCOPE ANY LOAD WITHIN THE LIMITS OF THE LOAD RATING CHART.
10. LIFTING OFF THE MAIN BOOM POINT WHILE THE SWING AROUND JIB IS ERECTED IS NOT INTENDED OR APPROVED.

INFORMATION

1. DEDUCTIONS MUST BE MADE FROM RATED LOADS FOR STOWED JIB, OPTIONAL ATTACHMENTS, HOOKS, AND LOADBLOCKS (SEE DEDUCTION CHART). WEIGHTS OF SLINGS AND ALL OTHER LOAD HANDLING DEVICES SHALL BE CONSIDERED A PART OF THE LOAD.
2. LOAD RATINGS ABOVE THE HEAVY LINE ARE STRUCTURALLY LIMITED CAPACITIES. LOAD RATINGS BELOW THE HEAVY LINE ARE STABILITY LIMITED CAPACITIES AND DO NOT EXCEED 85 % OF TIPPING.

DEFINITIONS

1. OPERATING RADIUS IS THE HORIZONTAL DISTANCE FROM THE AXIS OF ROTATION TO THE CENTER OF THE VERTICAL HOIST LINE OR TACKLE WITH LOAD APPLIED.
2. LOADED BOOM ANGLE IS THE INCLUDED ANGLE BETWEEN THE HORIZONTAL AND LONGITUDINAL AXES OF THE BOOM BASE AFTER LIFTING RATED LOAD AT RATED RADIUS.

ALLOWABLE LINE PULL										WARNING
1 PART LINE	2 PART LINE	3 PART LINE	4 PART LINE	5 PART LINE	6 PART LINE	7 PART LINE	8 PART LINE	9 PART LINE	10 PART LINE	
										<p>ANTI-TWO-BLOCK SYSTEM MUST BE IN GOOD OPERATING CONDITION BEFORE OPERATING CRANE.</p> <p>REFER TO THE OWNER'S MANUAL.</p> <p>KEEP AT LEAST 3 WRAPS OF LOAD LINE ON THE DRUM AT ALL TIMES.</p>
10000 LBS	20000 LBS	30000 LBS	40000 LBS	50000 LBS	60000 LBS	70000 LBS	80000 LBS	89900 LBS	89900 LBS	5/8" XLT4 LOW-TORQUE (3.5:1 SF) - 35000 LBS MIN BREAKING STRENGTH

AREA OF OPERATIONS

ON TIRES

WHEN LIFTING ON TIRES, THE BOOM MUST BE CENTERED OVER THE REAR OF THE CRANE WITH THE SWING BRAKE AND THE HOUSELOCK ENGAGED.

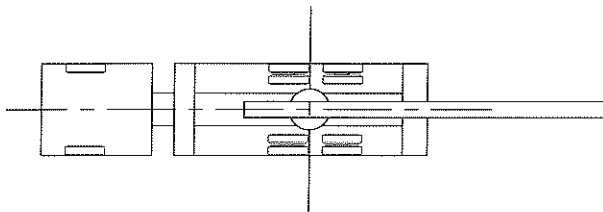

ON OUTRIGGERS

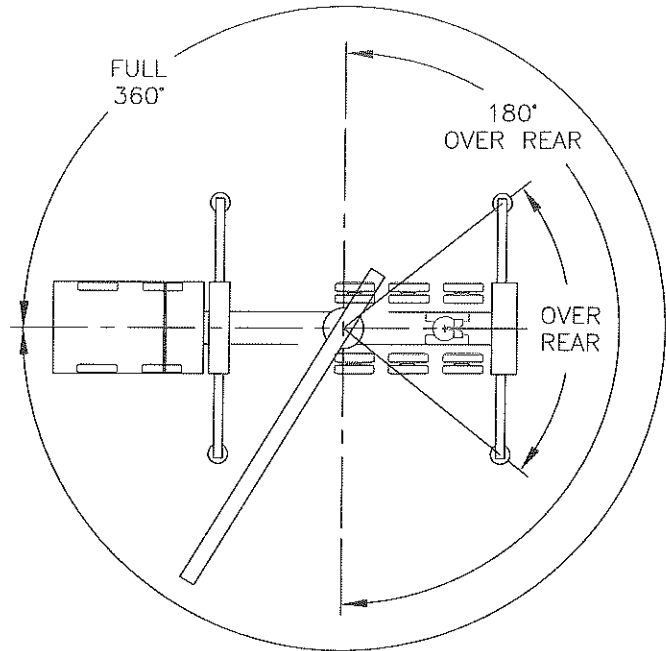

DEDUCTIONS FROM RATED LOADS FOR LOAD HANDLING DEVICES SUPPLIED BY MANITEX

AUXILIARY BLOCK	-----	50 LBS
ROOSTER SHEAVE	-----	70 LBS
LIFTING FROM MAIN BOOM WITH JIB STOWED OR ERECTED	-----	SEE LOAD CHART
OVERHAUL BALL	-----	SEE MANUFACTURER NAMEPLATE
LOAD BLOCK	-----	SEE MANUFACTURER NAMEPLATE

- RANGE DIAGRAM -

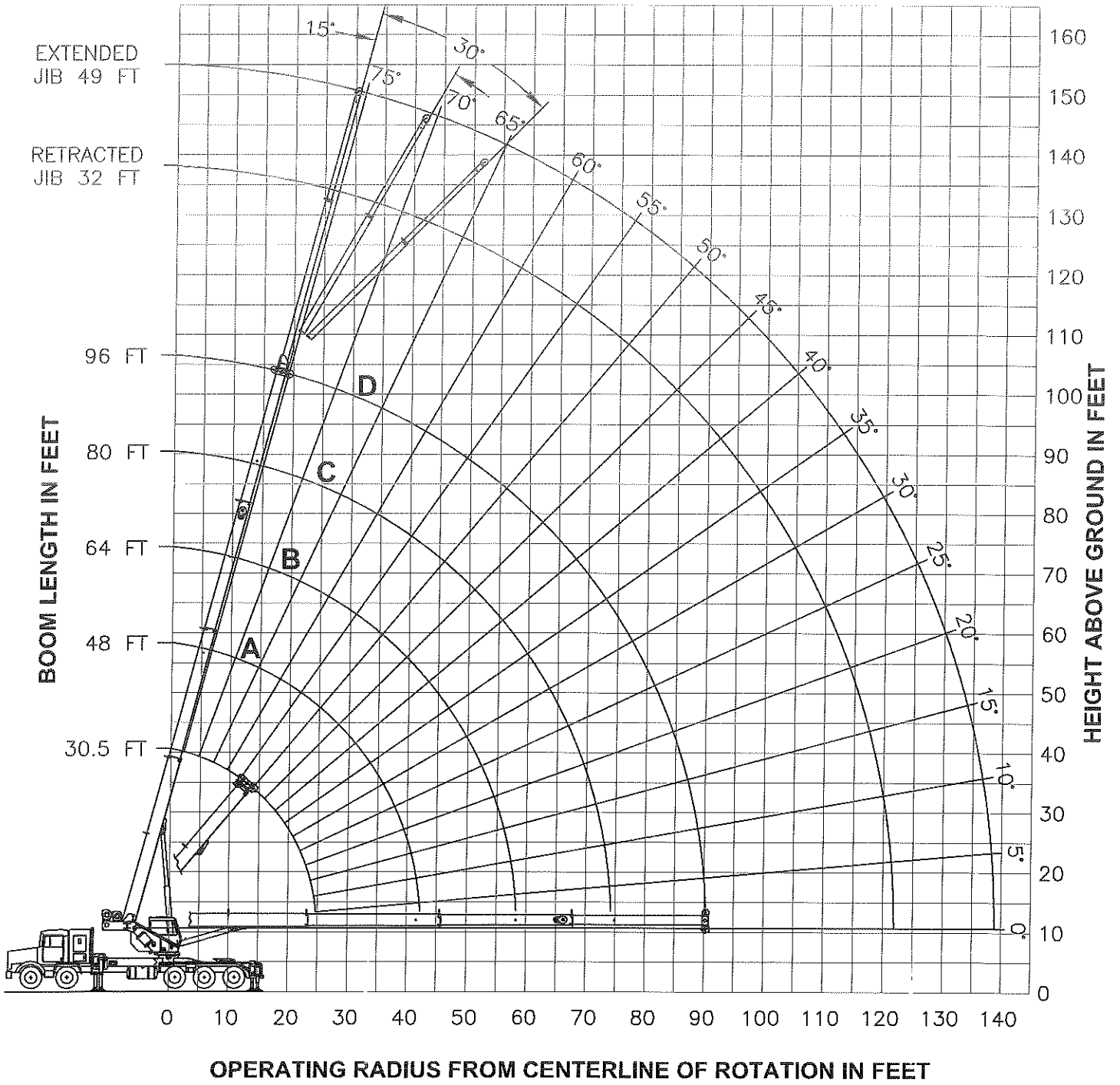

USE THIS CHART ONLY WHEN ALL OUTRIGGER BEAMS ARE FULLY EXTENDED

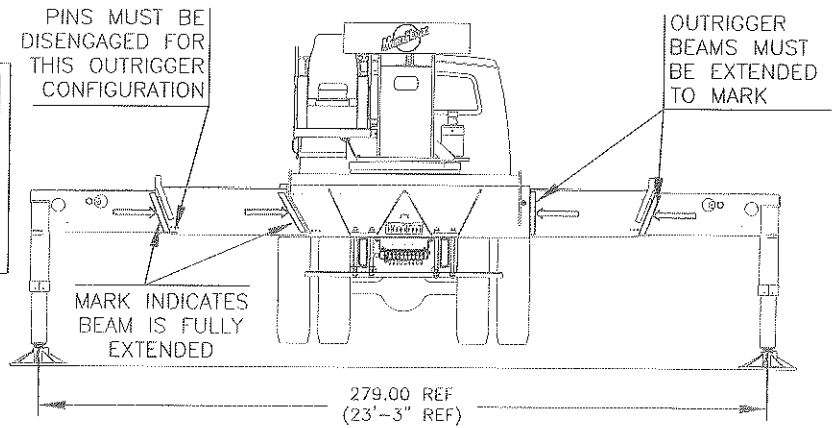

MAIN BOOM LIFTING CAPACITIES

LOAD RADIUS (FT)	BOOM LENGTH 30.5 FT				BOOM LENGTH 48 FT (A)				BOOM LENGTH 64 FT (B)						
	LOADED BOOM ANGLE (DEG)	CODE 1 OVER REAR (LBS)	CODE 2 180° OVER REAR (LBS)	CODE 3 FULL 360° (LBS)	LOADED BOOM ANGLE (DEG)	CODE 1 OVER REAR (LBS)	CODE 2 180° OVER REAR (LBS)	CODE 3 FULL 360° (LBS)	LOADED BOOM ANGLE (DEG)	CODE 1 OVER REAR (LBS)	CODE 2 180° OVER REAR (LBS)	CODE 3 FULL 360° (LBS)			
6	69	89990	89990	89990											
8	65	89990	89990	80100											
10	61	80000	80000	71300	73	51000	51000	51000							
12	56	70000	70000	64200	70	51000	51000	51000							
15	49	56000	56000	52100	66	51000	51000	51000	73	40000	40000	40000			
20	34	41800	41800	38200	59	42500	42500	39100	69	37650	37650	37650			
25					52	35100	35100	24840	64	30430	30430	25450			
30					44	29320	29320	16790	59	27040	27040	17330			
35					34	24420	22110	12170	53	24130	22620	12680			
40					20	20690	17330	9140	47	21110	17850	9660			
45									40	18220	14500	7540			
50									32	15890	12020	5960			
55									21	13960	10090	4730			
				1080 LBS					690 LBS					520 LBS	DEDUCT FOR JIB FROM MAIN BOOM CAPACITIES
				3050 LBS					2680 LBS					2520 LBS	STOWED JIB
				3470 LBS					2950 LBS					2720 LBS	ERECTED JIB (RETRACTED)
															ERECTED JIB (EXTENDED)

LOAD RADIUS (FT)	BOOM LENGTH 80 FT (C)				BOOM LENGTH 96 FT (D)									
	LOADED BOOM ANGLE (DEG)	CODE 1 OVER REAR (LBS)	CODE 2 180° OVER REAR (LBS)	CODE 3 FULL 360° (LBS)	LOADED BOOM ANGLE (DEG)	CODE 1 OVER REAR (LBS)	CODE 2 180° OVER REAR (LBS)	CODE 3 FULL 360° (LBS)						
20	74	27500	27500	27500										
25	70	24300	24300	24300	75	18000	18000	18000						
30	66	21280	21280	17630	72	17500	17500	17500						
35	62	19050	19050	12950	69	16240	16240	13130						
40	58	16980	16980	9920	65	14660	14660	10090						
45	53	15250	14760	7790	62	13280	13280	7950						
50	49	13800	12280	6220	58	12130	12130	6370						
55	44	12550	10370	5010	54	11080	10520	5160						
60	38	11460	8840	4040	50	10190	9000	4190						
65	31	10520	7600	3250	46	9600	7760	3400						
70	22	9960	6560	2580	41	8820	6730	2750						
75					36	8150	5860	2190						
80					30	7530	5120	1720						
85					23	6990	4470	1300						
90					8	6080	3880	920						
				410 LBS					350 LBS					DEDUCT FOR JIB FROM MAIN BOOM CAPACITIES
				2420 LBS					2360 LBS					STOWED JIB
				2580 LBS					2490 LBS					ERECTED JIB (RETRACTED)
														ERECTED JIB (EXTENDED)

**USE THIS CHART ONLY WHEN
ALL OUTRIGGER BEAMS ARE
IN THE MID POSITION**

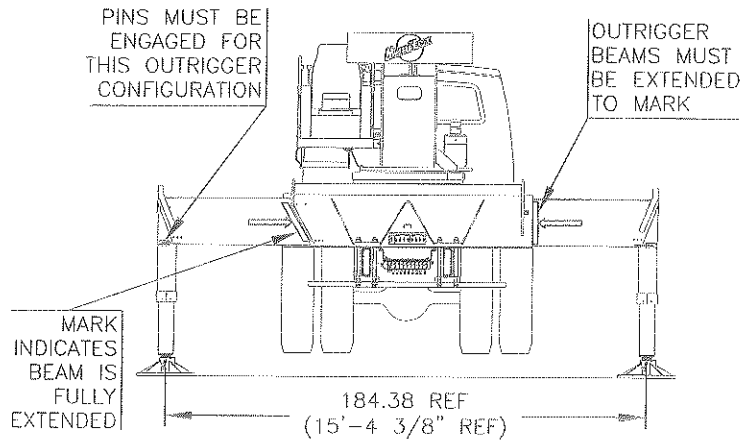

MAIN BOOM LIFTING CAPACITIES

LMI CODE 4										
LOAD RADIUS (FT)	BOOM LENGTH 30.5 FT		BOOM LENGTH 48 FT (A)		BOOM LENGTH 64 FT (B)		BOOM LENGTH 80 FT (C)		BOOM LENGTH 96 FT (D)	
	LOADED BOOM ANGLE (DEG)	FULL 360° (LBS)	LOADED BOOM ANGLE (DEG)	FULL 360° (LBS)	LOADED BOOM ANGLE (DEG)	FULL 360° (LBS)	LOADED BOOM ANGLE (DEG)	FULL 360° (LBS)	LOADED BOOM ANGLE (DEG)	FULL 360° (LBS)
6	69	89990								
8	65	89990								
10	61	80000	73	51000						
12	56	70000	70	51000						
15	49	50160	66	51000	73	40000				
20	34	27500	59	28830	69	29350	74	27500		
25			52	19100	64	19560	70	19820	75	18000
30			44	13720	59	14150	66	14390	72	14550
35			34	10300	53	10720	62	10950	69	11100
40			20	7890	47	8350	58	8570	65	8710
45					40	6600	53	6820	62	6960
50					32	5260	49	5490	58	5620
55					21	4190	44	4430	54	4570
60							38	3570	50	3710
65							31	2860	46	3000
70							22	2250	41	2410
75									36	1900
80									30	1460
85									23	1070
	1080 LBS	690 LBS	520 LBS	410 LBS	350 LBS	STOWED JIB				
	3050 LBS	2680 LBS	2520 LBS	2420 LBS	2360 LBS	ERECTED JIB (RETRACTED)				
	3470 LBS	2950 LBS	2720 LBS	2580 LBS	2490 LBS	ERECTED JIB (EXTENDED)				

DEDUCT FOR JIB FROM
MAIN BOOM CAPACITIES

**USE THIS CHART WHEN ALL
OUTRIGGER BEAMS ARE NOT IN
EITHER THE MID OR FULLY
EXTENDED POSITION**

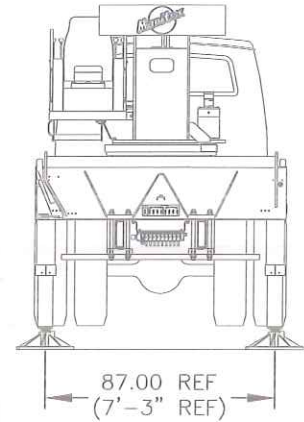

MAIN BOOM LIFTING CAPACITIES

LMI CODE 5												
LOAD RADIUS (FT)	BOOM LENGTH 30.5 FT		BOOM LENGTH 48 FT (A)		BOOM LENGTH 64 FT (B)		BOOM LENGTH 80 FT (C)		BOOM LENGTH 96 FT (D)			
	LOADED BOOM ANGLE (DEG)	FULL 360' (LBS)	LOADED BOOM ANGLE (DEG)	FULL 360' (LBS)	LOADED BOOM ANGLE (DEG)	FULL 360' (LBS)	LOADED BOOM ANGLE (DEG)	FULL 360' (LBS)	LOADED BOOM ANGLE (DEG)	FULL 360' (LBS)		
6	69	87500										
8	65	45070										
10	61	29250	73	30610								
12	56	20980	70	22160								
15	49	14000	66	15060	73	15500						
20	34	8010	59	9000	69	9390	74	9610				
25			52	5760	64	6130	70	6330	75	6470		
30			44	3740	59	4100	66	4300	72	4420		
35			34	2350	53	2710	62	2910	69	3030		
40			20	1310	47	1700	58	1900	65	2020		
45					40	930	53	1130	62	1250		
		1080 LBS	690 LBS		520 LBS		410 LBS		350 LBS		STOWED JIB	

DEDUCT FOR JIB FROM
MAIN BOOM CAPACITIES

WARNINGS

1. THE JIB MUST BE IN THE STOWED POSITION, IF SO EQUIPPED, WHEN USING THESE OUTRIGGER CONFIGURATIONS.

**USE THIS CHART
WHEN PICKING
LOADS ON TIRES**

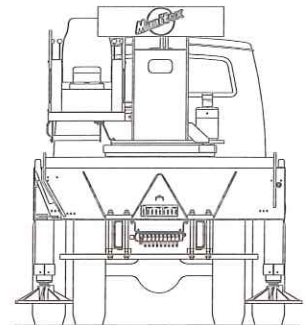

ON TIRE CAPACITIES

LMI CODE 6			
LOAD RADIUS (FT)	MAX BOOM LENGTH (FT)	BOOM DIRECTLY OVER REAR (LBS)	STOWED JIB DEDUCTION (LBS)
10	30.5	12000	1080
12	30.5	11000	1080
15	30.5	9500	1080
20	48 (A)	7500	690
25	48 (A)	5000	690
30	48 (A)	3500	690
35	48 (A)	2500	690
40	48 (A)	1600	690

WARNINGS

1. CRANE LOAD RATINGS ON TIRES ARE BASED ON THE CRANE BEING LEVEL AND TRAVELING ON A FIRM UNIFORM SURFACE (BLACK TOP, CONCRETE OR SIMILAR SURFACE).
2. TIRES MUST BE INFLATED TO 120 PSI FOR PICKING ON TIRES. CONSULT TRUCK MANUAL FOR PROPER INFLATION PROCEDURE.
3. THE JIB MUST BE IN THE STOWED POSITION, IF SO EQUIPPED, WHEN PICKING ON TIRES.
4. WHEN LIFTING ON TIRES, THE BOOM MUST BE CENTERED OVER THE REAR OF THE CRANE WITH THE SWING BRAKE AND THE HOUSELOCK ENGAGED.
5. KEEP THE LOAD CLOSE TO THE GROUND AND RESTRAINED FROM SWINGING.
6. WHEN THE RADIUS IS BETWEEN LISTED VALUES, USE THE SMALLER OF THE TWO LOAD RATINGS.
7. DO NOT OPERATE AT LONGER RADII THAN THOSE LISTED ON THE LOAD CHART.

**USE THIS CHART ONLY WHEN
ALL OUTRIGGER BEAMS ARE
FULLY EXTENDED**

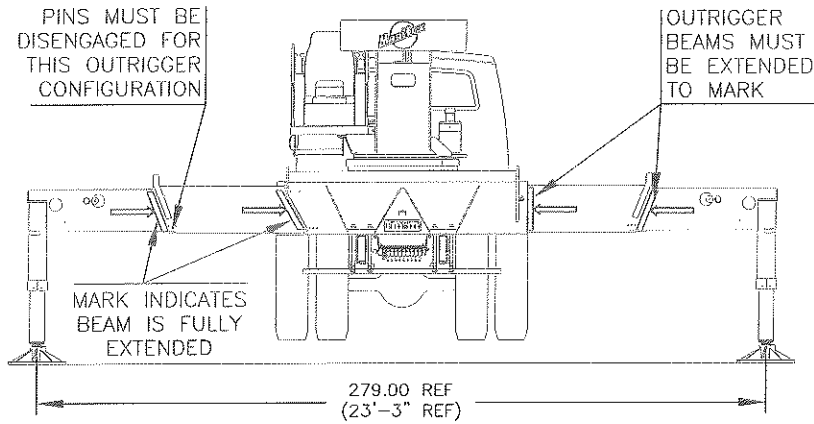

32 FT RETRACTED JIB LIFTING CAPACITIES

LOAD RADIUS (FT)	LOADED BOOM ANGLE (DEG)	0' OFFSET		15' OFFSET			30' OFFSET		
		CODE 7 OVER REAR (LBS)	CODE 8 180° OVER REAR (LBS)	LOADED BOOM ANGLE (DEG)	CODE 9 OVER REAR (LBS)	CODE 10 180° OVER REAR (LBS)	LOADED BOOM ANGLE (DEG)	CODE 11 OVER REAR (LBS)	CODE 12 180° OVER REAR (LBS)
40	73	8500	8500						
45	71	8320	8320	74	7600	7600			
50	68	7790	7790	72	7140	7140	74	5900	5900
55	66	7290	7290	69	6700	6700	72	5700	5700
60	63	6830	6830	66	6280	6280	69	5520	5520
65	61	6380	6380	64	5900	5900	66	5350	5350
70	58	5980	5980	61	5550	5550	63	5200	5200
75	55	5610	5610	58	5240	5240	60	5000	5000
80	52	5270	5130	55	4960	4960	57	4760	4760
85	49	4970	4480	52	4700	4700	54	4540	4540
90	46	4690	3910	49	4460	4140	51	4330	4320
95	42	4440	3410	45	4250	3610	47	4150	3750
100	38	4150	2960	41	4050	3130	43	3990	3240
105	34	3860	2560	37	3870	2710	38	3850	2780
110	29	3590	2200	32	3630	2320	32	3670	2360
115	23	3340	1880	25	3370	1950	24	3400	1950
120	14	3110	1580	14	3140	1600			

**USE THIS CHART ONLY WHEN
ALL OUTRIGGER BEAMS ARE
FULLY EXTENDED**

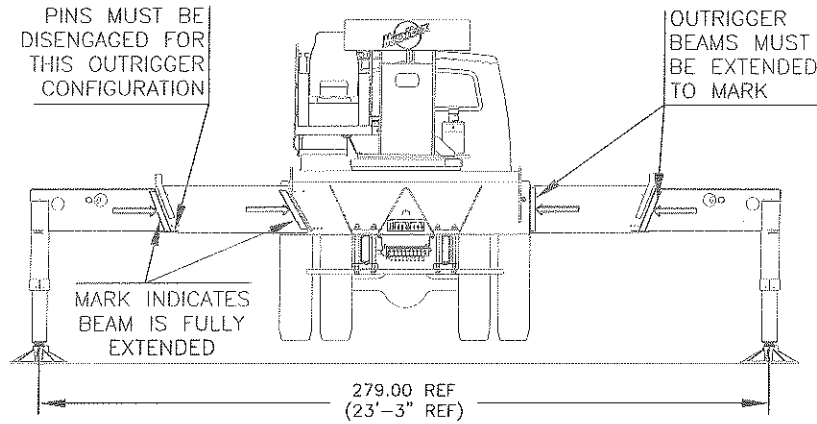

49 FT EXTENDED JIB LIFTING CAPACITIES

LOAD RADIUS (FT)	LOADED BOOM ANGLE (DEG)	0' OFFSET		15' OFFSET			30' OFFSET		
		CODE 13 OVER REAR (LBS)	CODE 14 180° OVER REAR (LBS)	LOADED BOOM ANGLE (DEG)	CODE 15 OVER REAR (LBS)	CODE 16 180° OVER REAR (LBS)	LOADED BOOM ANGLE (DEG)	CODE 17 OVER REAR (LBS)	CODE 18 180° OVER REAR (LBS)
45	73	5600	5600						
50	71	5600	5600	75	4530	4530			
55	69	5600	5600	73	4300	4300			
60	67	5300	5300	71	4080	4080	75	3350	3350
65	65	4960	4960	69	3900	3900	73	3230	3230
70	63	4670	4670	67	3710	3710	71	3120	3120
75	61	4400	4400	65	3550	3550	68	3020	3020
80	58	4160	4160	62	3410	3410	66	2930	2930
85	55	3940	3940	60	3270	3270	63	2850	2850
90	53	3730	3730	57	3150	3150	60	2770	2770
95	50	3550	3550	54	3030	3030	57	2710	2710
100	47	3380	3380	51	2930	2930	54	2650	2650
105	44	3230	3140	48	2830	2830	51	2600	2600
110	41	3090	2780	45	2750	2750	48	2550	2550
115	38	2960	2450	42	2670	2660	44	2520	2520
120	34	2840	2150	38	2600	2330	40	2510	2440
125	30	2730	1880	33	2550	2020	34	2510	2090
130	25	2630	1630	28	2510	1730	27	2510	1750
135	18	2540	1400	20	2500	1450			

**USE THIS CHART ONLY WHEN
ALL OUTRIGGER BEAMS ARE
IN THE MID POSITION**

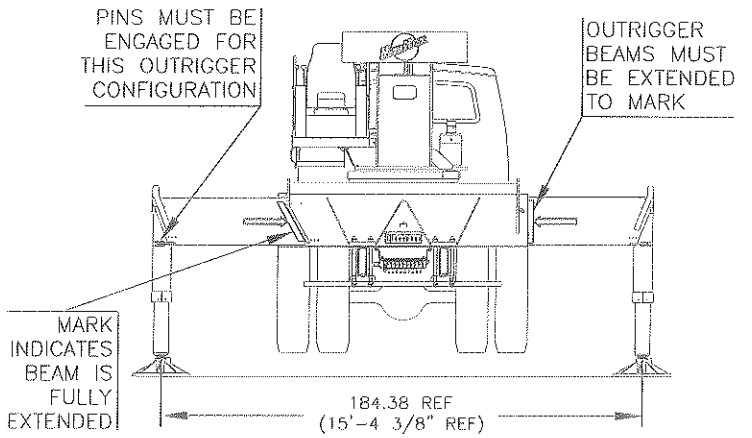

32 FT RETRACTED JIB LIFTING CAPACITIES

LOAD RADIUS (FT)	0' OFFSET		15' OFFSET		30' OFFSET	
	LOADED BOOM ANGLE (DEG)	CODE 19 180° OVER REAR (LBS)	LOADED BOOM ANGLE (DEG)	CODE 20 180° OVER REAR (LBS)	LOADED BOOM ANGLE (DEG)	CODE 21 180° OVER REAR (LBS)
40	73	8500				
45	71	6960	74	7600		
50	68	5600	72	6170	74	5900
55	66	4520	69	5020	72	5460
60	63	3640	66	4090	69	4460
65	61	2920	64	3320	66	3640
70	58	2320	61	2660	63	2950
75	55	1800	58	2110	60	2350
80	52	1360	55	1630	57	1840
85	49	970	52	1210	54	1390
90			49	840	51	990

49 FT EXTENDED JIB LIFTING CAPACITIES

LOAD RADIUS (FT)	0' OFFSET		15' OFFSET		30' OFFSET	
	LOADED BOOM ANGLE (DEG)	CODE 22 180° OVER REAR (LBS)	LOADED BOOM ANGLE (DEG)	CODE 23 180° OVER REAR (LBS)	LOADED BOOM ANGLE (DEG)	CODE 24 180° OVER REAR (LBS)
45	73	5600				
50	71	5600	75	4530		
55	69	5150	73	4300		
60	67	4270	71	4080	75	3350
65	65	3540	69	3900	73	3230
70	63	2920	67	3450	71	3120
75	61	2400	65	2870	68	3020
80	58	1950	62	2370	66	2740
85	55	1550	60	1940	63	2260
90	53	1210	57	1550	60	1840
95	50	900	54	1210	57	1460
100			51	910	54	1120
105					51	810